

Corner Track (Two Piece)

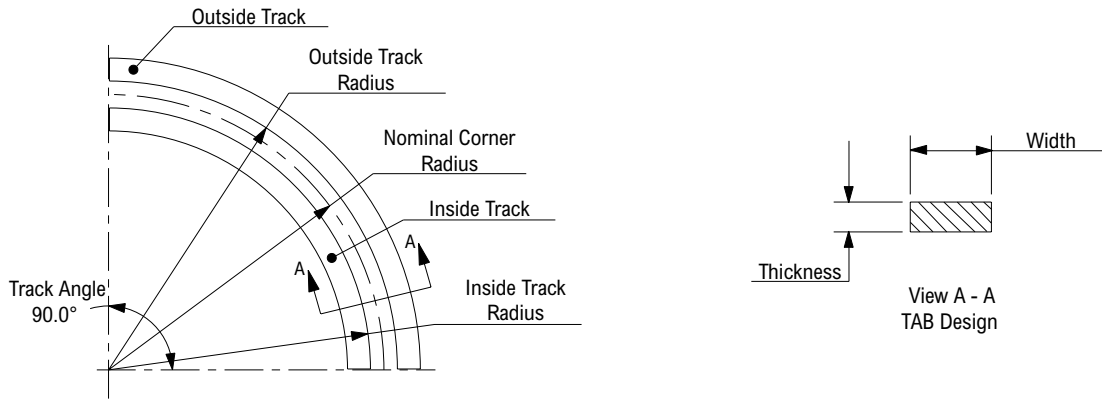

Corner track kit supplied as one 90° inside and one 90° outside track, which can be used as either carry or return.

Corner Track Kit Number	Accommodates Top Plate Width		Nominal Corner Radius		Inside Track Radius		Outside Track Radius		Thickness		Width		Material	Color	Approximate Corner Track Kit Weight	
	in	mm	in	mm	in	mm	in	mm	in	mm	in	mm			lbs	kg
TAB Design																
U18R6	All	All	18.0	457	17.3	439	18.7	475	0.75	19.1	1.50	38.1	UHMWPE	White	2.63	1.19
U24R6	All	All	24.0	610	23.3	592	24.7	627	0.75	19.1	1.50	38.1	UHMWPE	White	3.51	1.59

Corner Track (Four Piece)

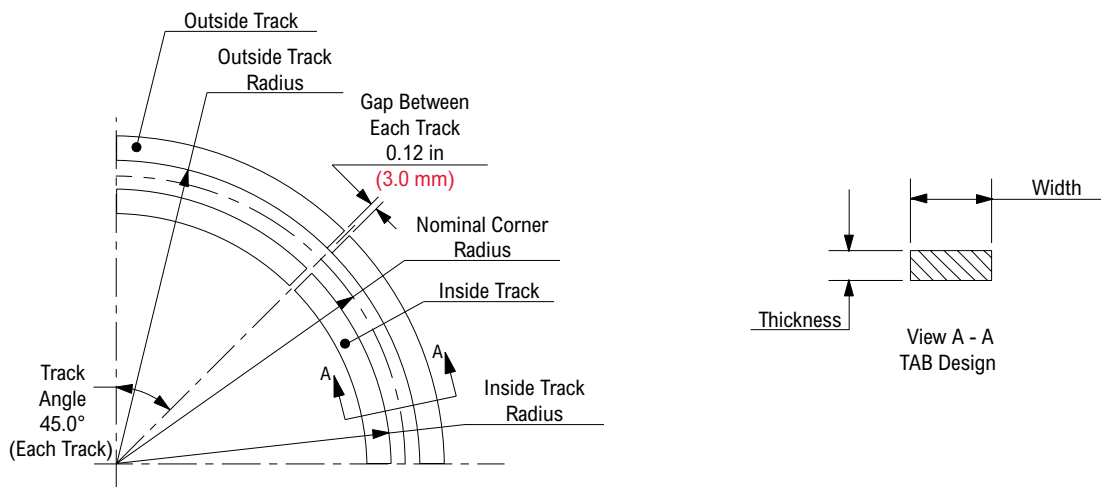

Corner track kit supplied as two 45° inside and two 45° outside track, which can be used as either carry or return.

Corner Track Kit Number	Accommodates Top Plate Width		Nominal Corner Radius		Inside Track Radius		Outside Track Radius		Thickness		Width		Material	Color	Approximate Corner Track Kit Weight	
	in	mm	in	mm	in	mm	in	mm	in	mm	in	mm			lbs	kg
TAB Design																
U30R6	All	All	30.0	762	29.3	744	30.7	780	0.75	19.1	1.50	38.1	UHMWPE	White	4.38	1.99

Gripper Attachments

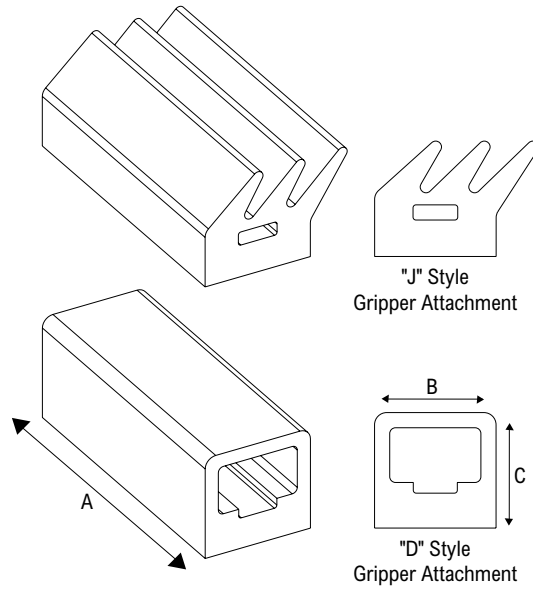

Part Number	Style	Material	Color	Hardness (Shore A)	"A" Dimension		"B" Dimension		"C" Dimension	
					in	mm	in	mm	in	mm
Standard Grippers										
114-582-7	D	EPDM	Black	50	3.35	85.1	1.25	31.8	1.19	30.2
114-647-5	J	EPDM	White	50	3.35	85.1	1.25	31.8	1.19	30.2
Made-to-Order Grippers										
114-582-1	D	Neoprene	Black	40	3.35	85.1	1.25	31.8	1.19	30.2
114-582-3	D	Neoprene	White	40	3.35	85.1	1.25	31.8	1.19	30.2
114-582-4	D	Neoprene	Black	60	3.35	85.1	1.25	31.8	1.19	30.2
114-582-5	D	EPDM	White	50	3.35	85.1	1.25	31.8	1.19	30.2
114-582-6	D	EPDM	White	80	3.35	85.1	1.25	31.8	1.19	30.2
114-647-1	J	Neoprene	Black	40	3.35	85.1	1.25	31.8	1.19	30.2
114-647-2	J	Neoprene	White	50	3.35	85.1	1.25	31.8	1.19	30.2
114-647-4	J	EPDM	White	80	3.35	85.1	1.25	31.8	1.19	30.2